

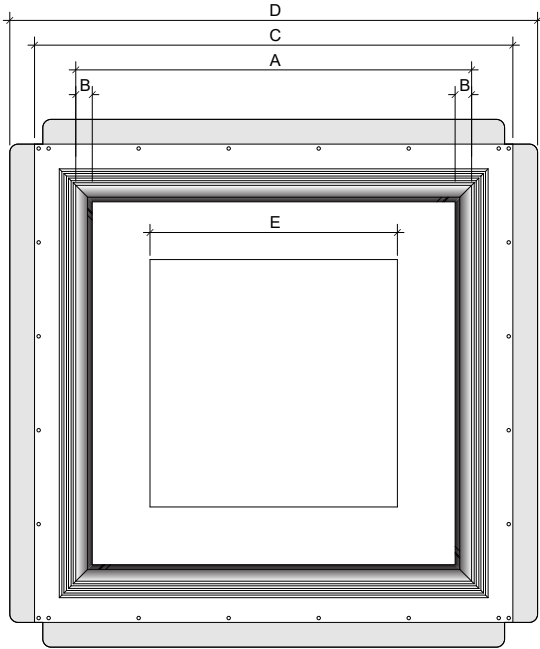

ARCHITECTURAL SQUARE DIFFUSERS WITH LIGHT MODEL #  
SL1201088

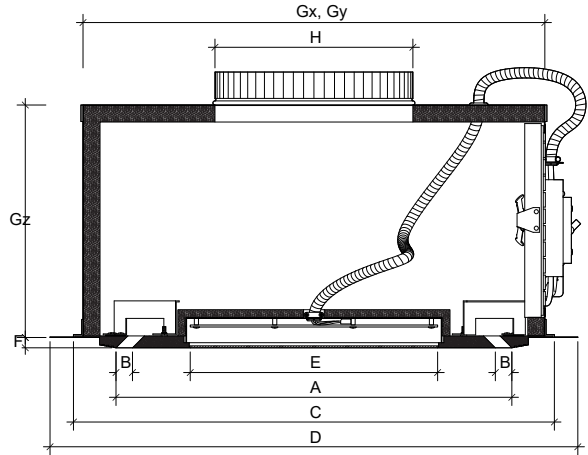

front view



section

**KEY FEATURES:**

- Tape and spackle installation
- ASTM E-84 Class A rated

**NOTES:**

- Custom plenum box provided by Invi, with minimum 12" height
- Diffuser face removable with magnets for access to light assembly
- Light assembly and plenum box lined with foam rubber insulation

**PRODUCT DIMENSIONS**

MODEL #	(A) DIFFUSER OPENING	QTY	# SLOTS	(B) SLOT WIDTH	(C) REQ. CEILING FRAME OPENING	(D) OVERALL PRODUCT SIZE	(E) LIGHT SIZE	LIGHT TEMP. (WARM /COOL)	(F) GYPSUM BOARD THICKNESS (SPECIFY)
SL1201088	12" x 12"		1	7/8"	16 1/2" x 16 1/2"	19" x 19"	5"		
SL1201088	12" x 12"		1	7/8"	16 1/2" x 16 1/2"	19" x 19"	5"		

**PLENUM BOX SPECIFICATIONS**

(Gx) PLENUM LENGTH	(Gy) PLENUM WIDTH	(Gz) PLENUM HEIGHT (SPECIFY)	QUANTITY	DUCT CONNECTION TYPE	(H) COLLAR SIZE	COLLAR LOCATION (TOP / SIDE)	NOTES / OTHER SPECS
14"	14"						
14"	14"						
14"	14"						
14"	14"						
14"	14"						

CONTRACTOR	
PROJECT	
ADDRESS	
ENGINEER	
PREPARED BY	

InviAir  
67 Guernsey St  
Brooklyn, NY 11222  
917-909-0343